

AxialTQ™ WIRELESS ROTARY TORQUE TRANSDUCER

The Interface AxialTQ torque measurement system was developed in direct collaboration with over 30 end-users who shared their wish-lists for operational priorities, user interface, design, features, real-world field issues and more.

AxialTQ torque measurement system redefines the category in terms of function, accuracy and customizable compatibility.

The rotor sensing element and electronics are the heart of the system which will be offered in 8 torque capacities in 5 DIN sizes. With the flexible capability of stator and output module mounting, the AxialTQ system offers an infinite number of configurations to meet any application need.

SPECIFICATIONS

ACCURACY / DATA RATE				
Model	EX			
Accuracy Class	0.05			
Temp Effect on Zero – %RO/10°C	±0.05			
Temp Effect on Output – %RO/10°C	±0.05			
Data Rate (max) samples/sec	5K			
Accuracy Class Output	Analog or digital			
DIN Size	Capacity		Rated Speed	
	U.S. (lbf-in)	Metric (Nm)	Nominal	Extended (0.10% Accuracy Class)
100	885, 2.21K	100, 250	15K	20K
120	4.42K, 8.85K	500, 1K	14K	20K
150	17.7K, 26.5K	2K, 3K	11K	15K
180	44.2K	5K	7K	10K
225	88.5K	10K	5K	6K
ENVIRONMENTAL				
Compensated Operating Range	°F	+50 to +158		
	°C	+10 to +70		
Maximum Operating Range	°F	+4to +158		
	°C	-20 to +70		
Storage Range	°F	-40 to +185		
	°C	-40 to +85		
ELECTRICAL				
Output Types	Voltage, Frequency, USB			
Power Supply – VDC	24 ± 6			
ANALOG OUTPUT				
10 kHz ± 5kHz	± 10 VDC			
60 kHz ± 3Q0kHz	± 5 VDC			
60 kHz ± 20kHz	12 mA ± 8 mA			
MECHANICAL				
Safe Overload – % RO	200			
Rotor / Stator Axial Gap	in	0.118 ± 0.078		
	mm	3 ± 2		
Radial Clearance	in	0.472		
	mm	12		
IP Rating	IP65			
DIN Size	100	120, 150, 180, 225		
Material	Aluminum	Steel		

STANDARD CONFIGURATION



Model ATQ10D12-01KEX (Shown)

MODELS

AxialTQ-EX

- Designed to minimize uncertainty while covering a broad array of torque measurement applications.
- An accuracy class of 0.05 with an axial gap and dual analog and digital simultaneous outputs.

FEATURES & BENEFITS

- Crash-Proof Design for Maximum Reliability
- Versatile Design for Application Flexibility
- Flexible Configuration
- Simultaneous Analog and Digital Outputs Enables Real-time Control and Data Collection
- Interchangeable Stators and Output Modules to Minimize Parts Inventory
- Wide Range of Standard Components to Match Any Application

OPTIONS

- Balanced Rotor to G2.5
- Speed Sensing 60 PPR

Euro Pat App 3 662 236

International System of Units (SI) dimensions and capacities are provided for conversion only. Standard products have U.S. capacities and dimensions. SI

AxialTQ™ WIRELESS ROTARY TORQUE TRANSDUCER

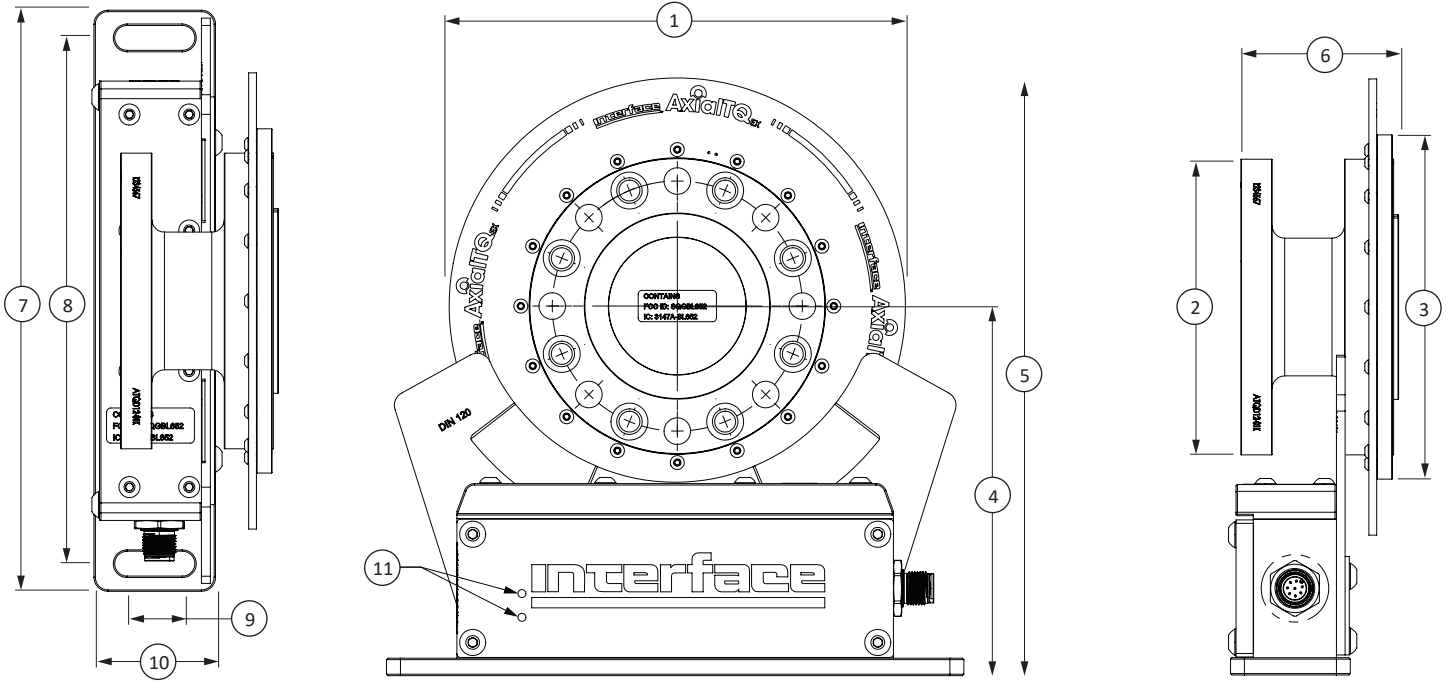

DIMENSIONS

Din Size	100		120		150		180		225	
Torque Capacity	U.S. (lbf-in)	Metric (Nm)	U.S. (lbf-in)	Metric (Nm)	U.S. (lbf-in)	Metric (Nm)	U.S. (lbf-in)	Metric (Nm)	U.S. (lbf-in)	Metric (Nm)
	885, 2.21K	100, 250	4.42K, 8.85K	500, 1K	17.7K, 26.5K	2K, 3K	44.2K	5K	88.5K	10K
See Drawing	in	mm	in	mm	in	mm	in	mm	in	mm
(1)	6.57	167	7.28	185	8.66	220	9.60	244	11.29	287
(2)	∅3.93	∅100	∅4.72	∅120	∅5.90	∅150	∅7.08	∅180	∅8.85	∅225
(3)	∅4.60	∅117	∅5.51	∅140	∅6.69	∅170	∅7.87	∅200	∅9.64	∅245
(4)	5.23	133	5.66	144	6.33	161	6.90	175.5	7.83	199
(5)	8.54	217	9.29	236	10.66	271	11.73	298	13.50	343
(6)	2.15	54.8	2.44	62	2.44	62	2.44	62	2.44	75.7
(7)	8.26	210	8.26	210	8.26	210	8.26	210	8.26	210
(8)	7.48	190	7.48	190	7.48	190	7.48	190	7.48	190
(9)	0.78	20	0.78	20	0.78	20	0.78	20	0.78	20
(10)	1.73	44	1.73	44	1.73	44	1.73	44	1.73	44
(11)	2 x LED Indicator Lights									

AxialTQ™ WIRELESS ROTARY TORQUE TRANSDUCER

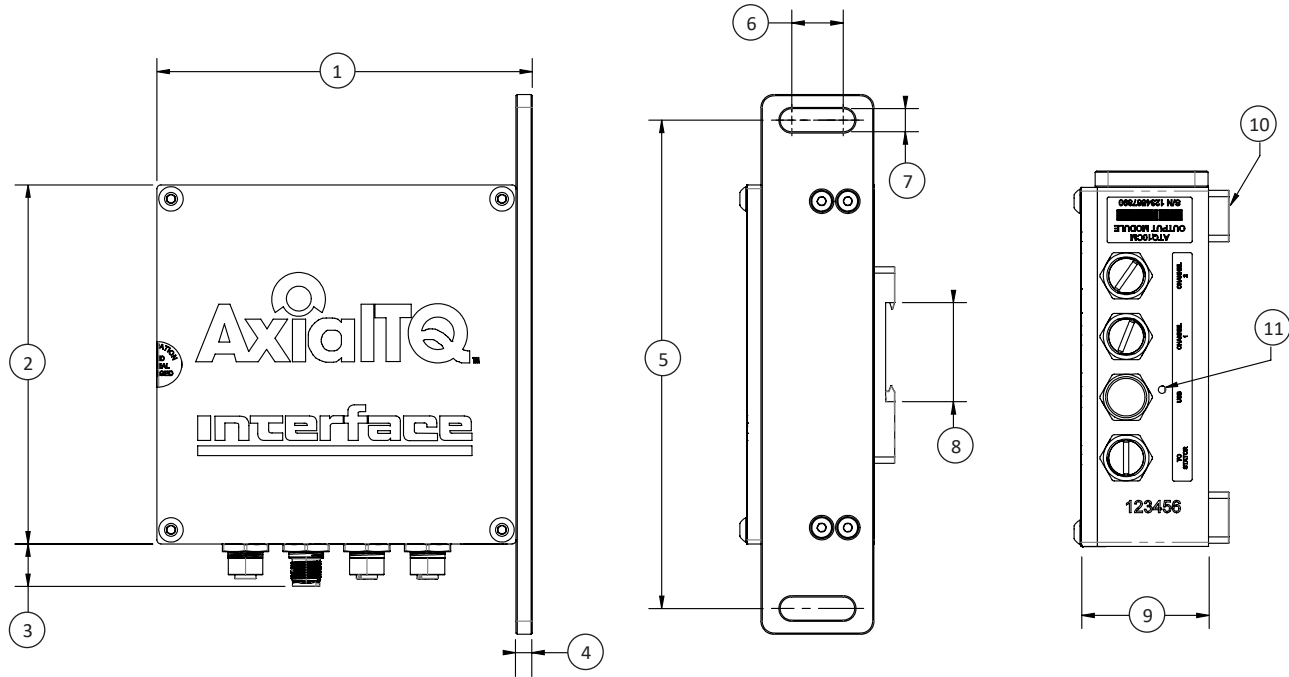

DIMENSIONS

See Drawing	in	mm
(1)	5.75	146.1
(2)	5.50	139.7
(3)	0.65	16.6
(4)	0.25	6.4
(5)	7.48	190.0
(6)	0.79	20.0
(7)	0.35	9.0
(8)	1.52	38.5
(9)	1.95	49.5
(10)	DIN RAIL: TS35	
(11)	2 x LED Indicator Lights	

AxialTQ™ WIRELESS ROTARY TORQUE TRANSDUCER

SYSTEM ARCHITECTURE

