

ELECTRICAL INFORMATION

Load Cell Series	Cell Type	Upscale (4) Mode	Integral Cable Wiring	Std. Cable Type	Cable Length, Feet (5)	Connector Wiring	Mating Connector (2)
1000	Univ.	Tension	W1	A	10	C1	PC06W-10-6S(SR)
1100	Univ.	Tension	W1	A	10	C1	PC06W-10-6S(SR)
1100	Comp.	Tension	W1	A	10	C1	PC06W-10-6S(SR)
1200	Univ.	Tension	W1	A	10	C1	PC06W-10-6S(SR)
1200	Comp.	Tension	W1	A	10	C1	PC06W-10-6S(SR)
1500	Univ.	Tension	-	-	-	C1	PT06A-10-6S(SR)
1600	Univ.	Tension	-	-	-	C2	PT06A-12-8S(SR)
1600	Comp.	Tension	-	-	-	C2	PT06A-12-8S(SR)
1700	Univ.	Tension	-	-	-	C6	PT06A-10-6S(SR)
1800	Univ.	Tension	-	-	-	C2	PT06A-12-8S(SR)
3200	Univ.	Tension	W2	B	20	-	-
3200	Comp.	Tension	W2	B	20	-	-
4200	Comp.	Tension	W2	B	20	-	-
4600	Comp.	Tension	W2	B	20	-	-
5200	Univ.	Tension (1)	W1	A	10	C1	PC06W-10-6S(SR)
SSB	Comp.	Comp.	W2	C	5	-	-
MB, MBP	Comp.	Comp.	W2	C	5	-	-
SM	Univ.	Tension	W2	C	5	-	-
SSM	Univ.	Tension	W2	A	10	C1	PC06W-10-6S(SR)
SMT	Univ.	Tension	W2	D	5	-	-
SPI	Univ.	Comp.	W2	C	5	-	-
SML	Univ.	Tension	W2	D	5	-	-
LBM	Comp.	Tension	W3	G	5	-	-
LBS	Comp.	Tension	W2	G	5	-	-
LW	Comp.	Comp.	W2	-	5	-	-
WeighCheck	Comp.	Tension	W2	B	30	-	-
WMC	Univ.	Tension	W3	G	-	-	-
WMC ≥15K	Univ.	Tension	-	-	-	C3	PT06A-10-6S(SR)
2410-2430	Univ.	Tension	-	-	-	C3	PT06A-10-6S(SR)
2440-2450	Univ.	Tension	-	-	-	C3	MS3106A-145-6S
2100	Univ.	Tension	-	-	-	C4	MS3106A-145-6S
2100	Comp.	Tension	-	-	-	C4	MS3106A-145-6S
MRT	Torque	CW	W2	D	5	-	-
ULC	Univ.	Tension	W2	D	5	-	-
MCC	Comp.	Comp.	W2	E	5	-	-
CX	-	-	-	-	--	C5	PT06A-12-8S(SR)

- Note:
- 1) Thrust axis only.
 - 2) Mating connector for the stock version of cell. Consult factory for alternate connectors and specials.
 - 3) Consult factory. Several connectors and mating cable types are available.
 - 4) Indicates the loading direction which causes a positive output.
 - 5) Stock length; other lengths available on special order.

LOAD CELL INTEGRAL CABLES				
Cable Type	Wire Size	No. of Wires	Shield	Description
A	22 AWG	7	Braid	Heavy-duty, PVC jacket
B	22 AWG	4	Braid	Heavy-duty, polyurethane jacket
C	28 AWG	4	Braid	Tough, clear PVC jacket
D	28 AWG	4	Spiral	Ultra-flexible, black PVC jacket
E	30 AWG	4	Braid	Ultra-flexible, gray PVC jacket
F	20 AWG	4	Braid	Teflon jacket
G	30 AWG	4	Braid	Teflon jacket

ELECTRICAL INFORMATION

LOAD CELL CABLE WIRING

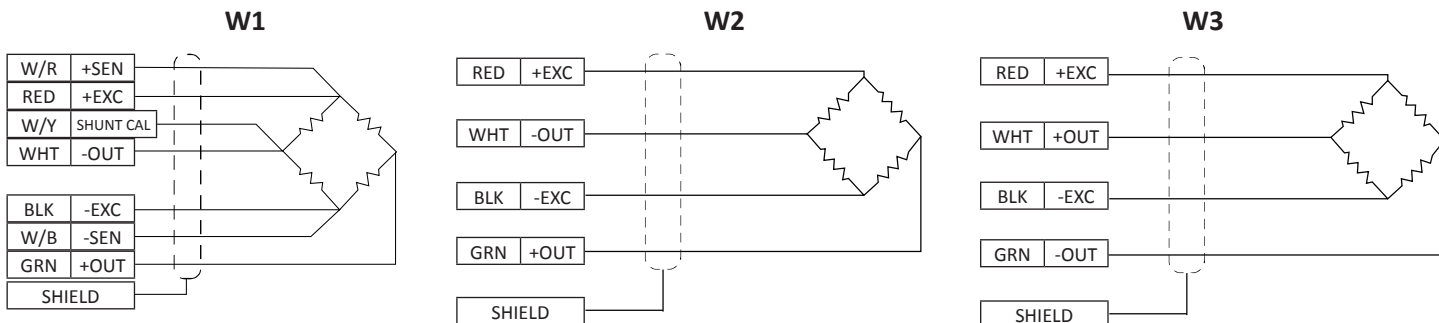

LOAD CELL CONNECTOR WIRING

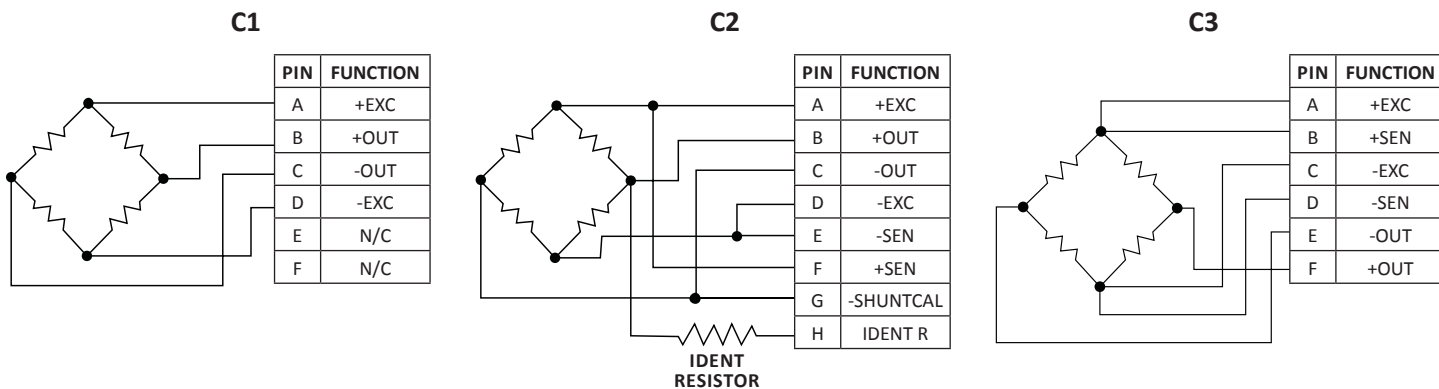

C1 with TEDS option

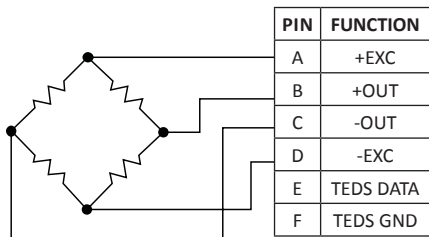

C2 with TEDS option

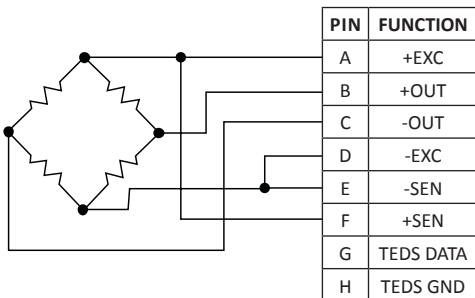

C3 with TEDS option

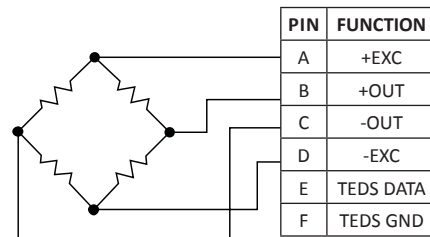

C4

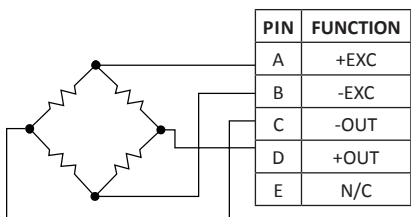

C5

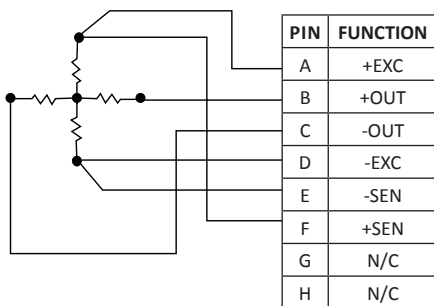

C6

