

JB104SS Junction Box

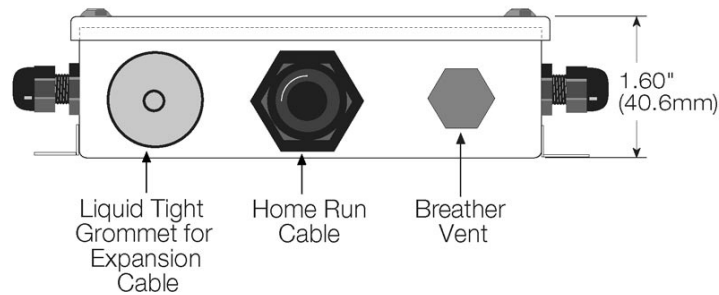
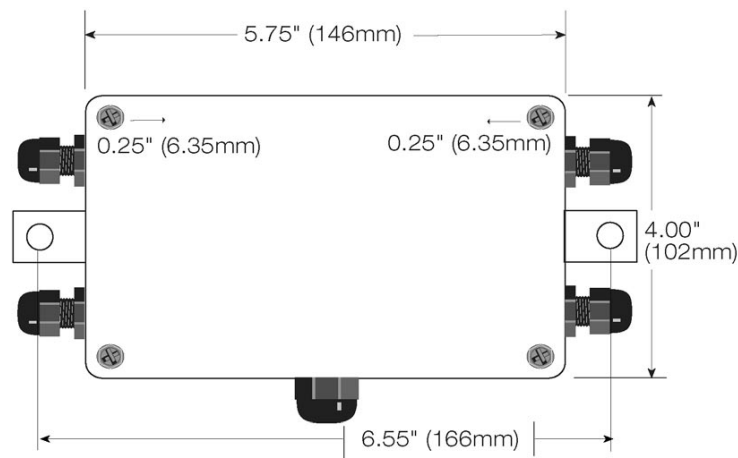

1 Mounting the Small Junction Box

The junction box should be mounted in a location that is convenient for servicing and away from standing water. Try to mount the enclosure in a location so that the load cell cables need not be cut, nor length added. Load cell output is temperature compensated for the supplied cable length. Altering that length can change the cell's signal output.

Depending on the mounting surface, the JB104SS enclosure can be attached using two pan-head screws, bolts, or other suitable fasteners. Figure 1 below shows the dimensions for mounting the enclosure

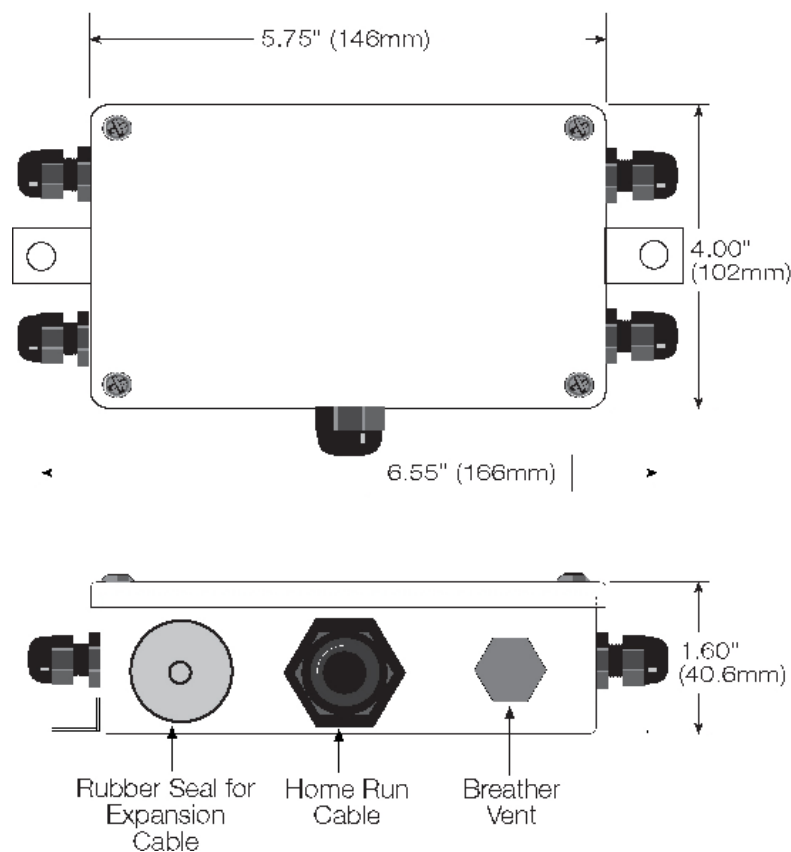

Figure 1: JB104SS Enclosure Dimensions

2 Wiring the Junction Box

The JB104SS junction box model has been designed to connect and trim up to four load cells per board. However it is possible to use this box with other combinations. Use the expansion port on the main board (shown below), to connect multiple junction boxes in series to accommodate applications that have more than four load cells.

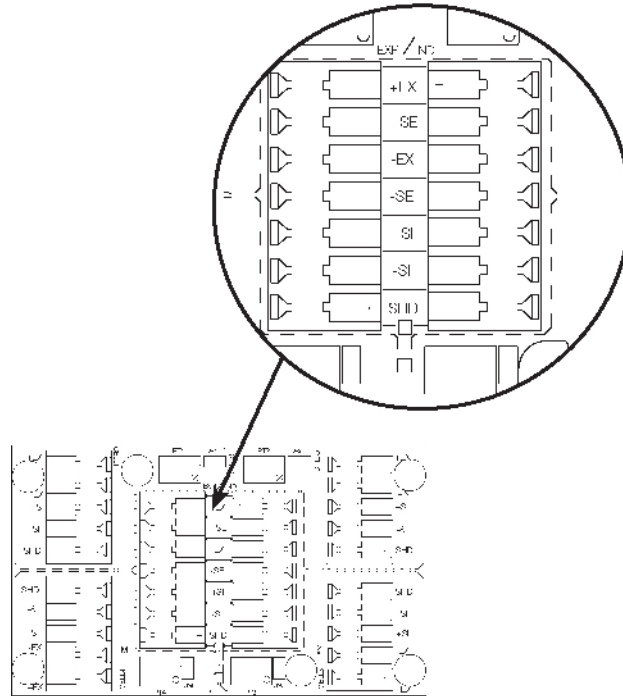

Figure 2: Expansion Port Location

After determining the wiring pattern, route the load cell cables through the cord grip assemblies and leave the grips loose until final closure. Before connecting load cell wires to the terminals, strip the wire insulation back 1/4" to expose the wire. The spring-loaded terminals will accommodate 12 to 28 gauge wire. To connect the load cell wires to the appropriate connectors, push in the quick-connect lever with a small screwdriver. While holding in the lever, insert the appropriate wire into the exposed wire opening. Release the screwdriver to allow the spring-loaded gate to close and lock the wire in place.

The indicator terminal strip is used to connect the main cable to the indicator. Determine the indicator's load cell input connections from the operating manual. Run a cable from your indicator terminal into the junction box through the larger cord grip and make the connections on the indicator terminal using the same procedure as inserting load cell cables to the appropriate connectors.

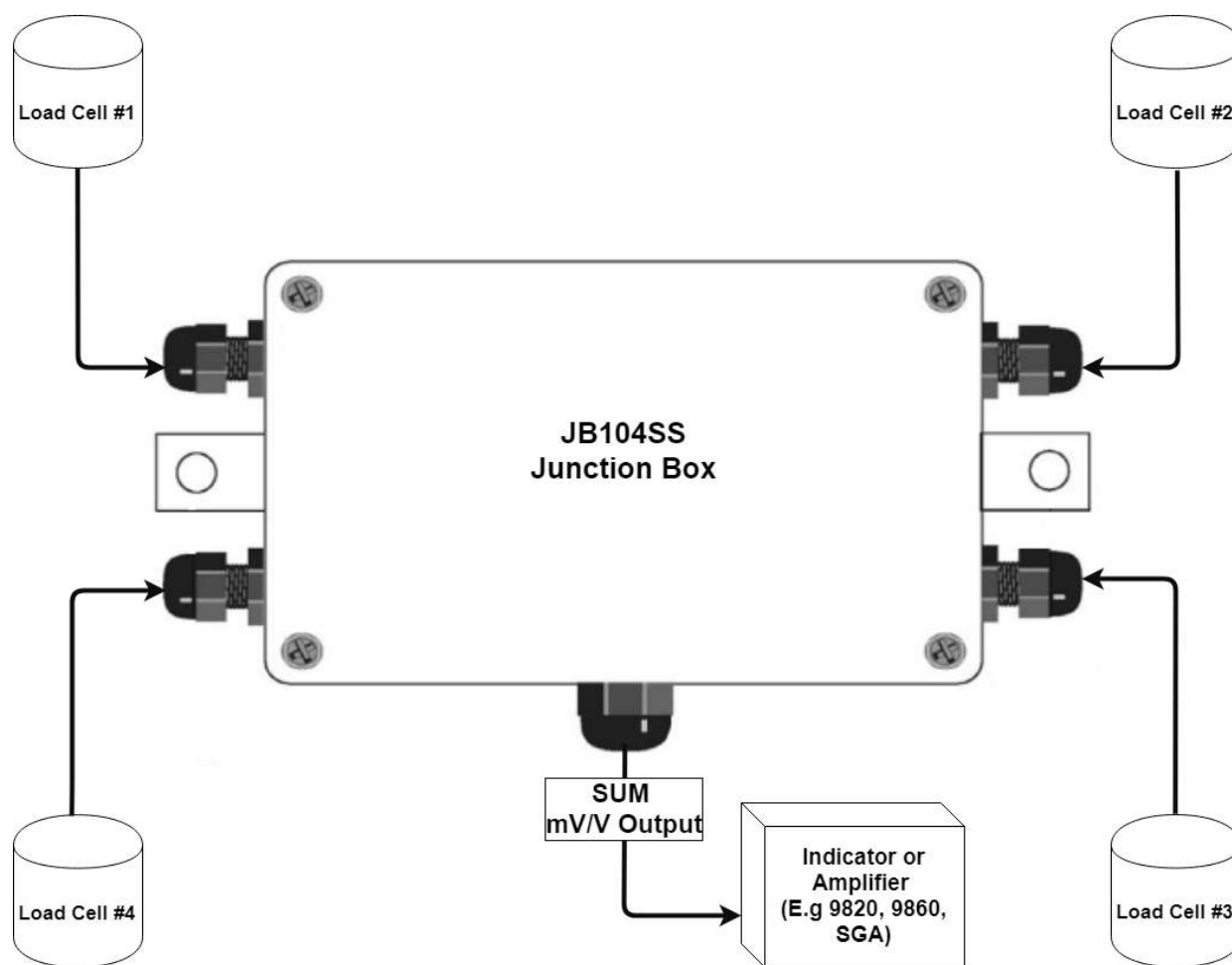
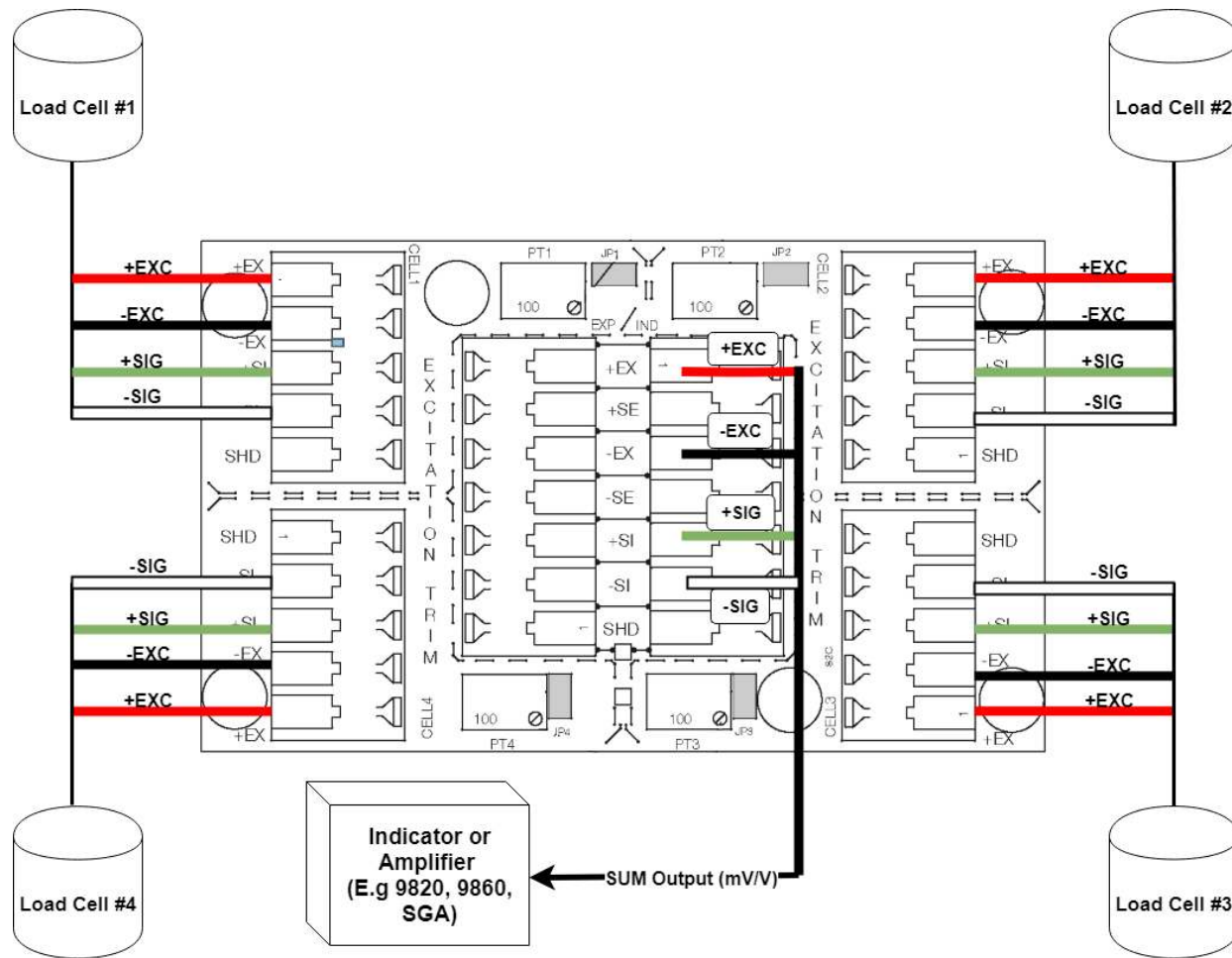

Figure 3: Application Use

JB104SS Wiring	
Load Cell	Color
+EXC	RED
-EXC	BLK
+SIG	GRN
-SIG	WHT
+SE	RED/WHT
-SE	BLK/WHT

Figure 4: JB104SS Wiring

NOTE – If Tension Positive (Reverse Polarity) Swap Green and White Leads



(NOTE: If Reverse Polarity, Swap Green and White Lead)

Figure 5: Wiring Diagram

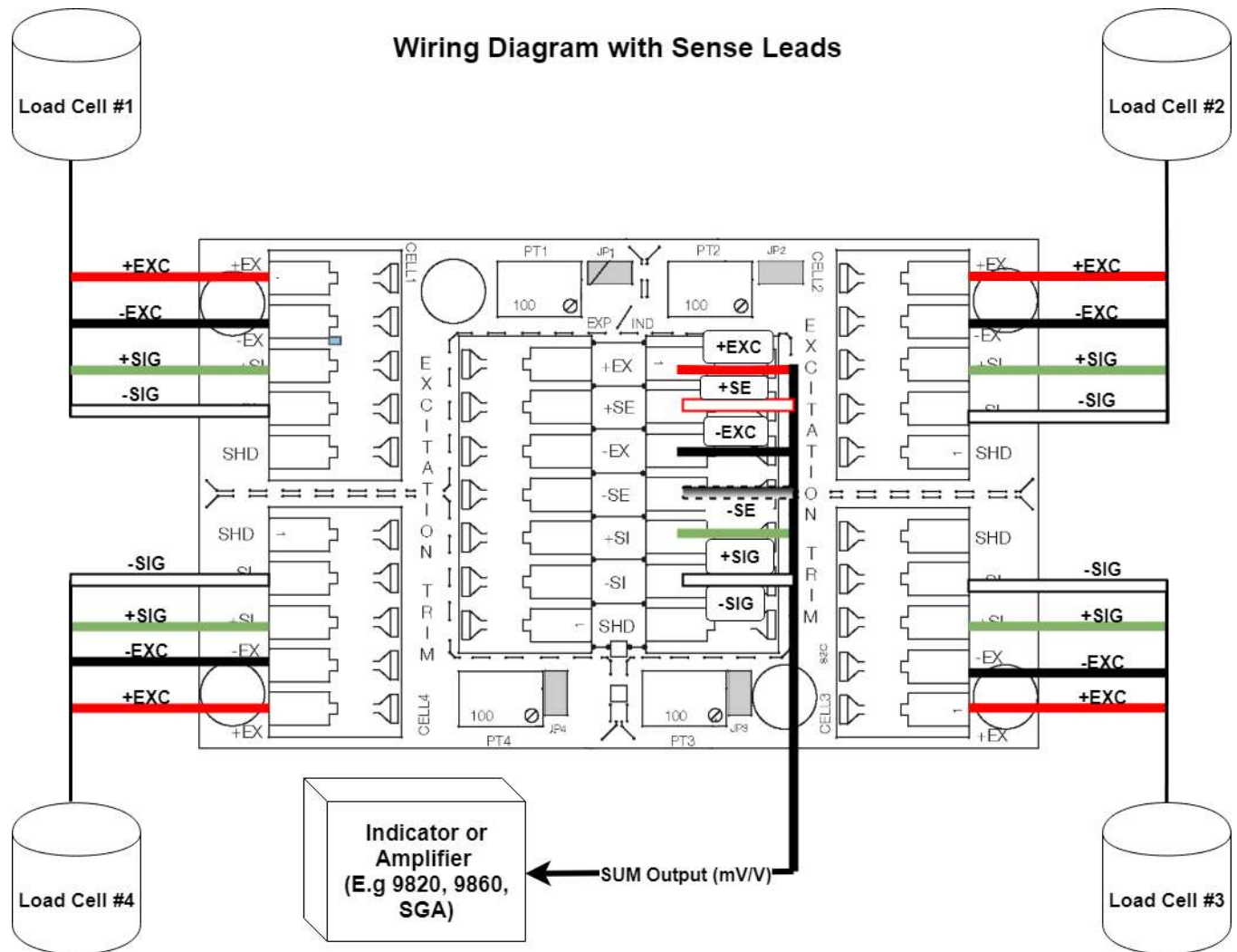

(NOTE: If Reverse Polarity, Swap Green and White Lead)

Figure 6: Wiring Diagram with Sense Leads

3 Trimming Procedure

Trimming is a process of equalizing the output from multiple individual load cells. If needed, load cell output can be individually trimmed with potentiometers.

Whenever a substantial amount of trim (more than 5% of normal output), seems necessary to equalize output check for other possible problems. The best trim is always the least amount of trim. When all errors except the cell mismatch and cable extensions or reductions have been corrected, continue with the trimming.

3.1 Excitation Board Trimming Procedure

Use the following steps to properly trim the JB104SS junction box.

1. Determine the number of load cells needed.
2. *Make sure jumpers have been removed to enable trimming of the desired cells corresponding to each load cell in use.* See Figure 3 for the location of jumpers JP1, JP2, JP3 and JP4. Note that jumpers *must* be removed to enable trimming on the excitation board.
3. Set all potentiometers fully clockwise to give maximum signal output from each cell (see location of potentiometers below).

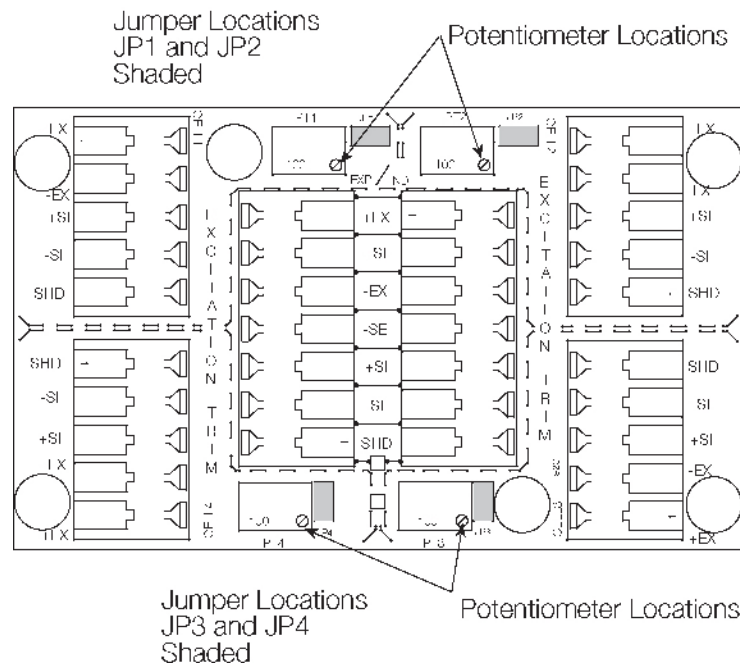

Figure 7: Excitation Main Board

4. Zero the indicator and place calibrated test weights over each load cell in turn. The amount of test weights to be used will depend on the scale configuration; for specific recommendations, refer to Handbook 44 Field Manual, published by the Institute for Weights and Measures. For a four-cell platform, it's recommended using 25% of scale capacity.
5. Record the value displayed on the indicator after the test weight is placed in turn on each corner (directly over the load cell) without allowing the weight to overhand the sides. Allow the scale to return to zero each time to check for friction or other mechanical problems. Select the load cell which has the lowest value as your reference point. This cell will not be trimmed.
6. Replace the same test load over each cell in turn. Using the corresponding potentiometer, trim each cell down to equal the reference load cell. As corner corrections are somewhat interactive, check all cells again for repeatability. If necessary, repeat steps 4 and 5.
7. Pull excess cable out of the enclosure and tighten the cord grip assemblies with a wrench. To be watertight, each cord grip must be tightened so the rubber sleeve begins to protrude from the hub.
8. Unused hubs must be properly plugged to prevent moisture entry. If extra hole plugs are needed please consult factory.
9. Remove the desiccant from the plastic bag, and insert the desiccant bag into the junction box before closing. Inspect the desiccant during normal service and change desiccant as needed.
10. Replace the cover and tighten the cover screws in an alternating pattern to be certain the gasket is compressed equal in all locations.