

Model 5200 Multi-Axis Load Cell

Why the Interface model 5200 Multi-Axis Load Cell is the best in class:

- Simultaneously measure thrust and moment perpendicular to the thrust axis
- Thrust axis functions to the same specifications as a Model 1200
- Thrust stiffness and moment stiffness are both very high because of the low profile construction



Base included

SPECIFICATIONS

Static Error Band–Thrust, 300-2K±0.04
5K-50K±0.05
100K±0.06
Deflection–Thrust, FS0.001 to 0.002 inches (depending on range)
Calibration–ThrustSame as 1200 Series Universal [†]
Deflection–Moment, FSfrom 20 seconds (depending on range)
Output–Moment, mV/VApprox. 1/2 of rated thrust output
Cross-Talk–Moment1% or less
Calibration Uncertainty–Moment±1%

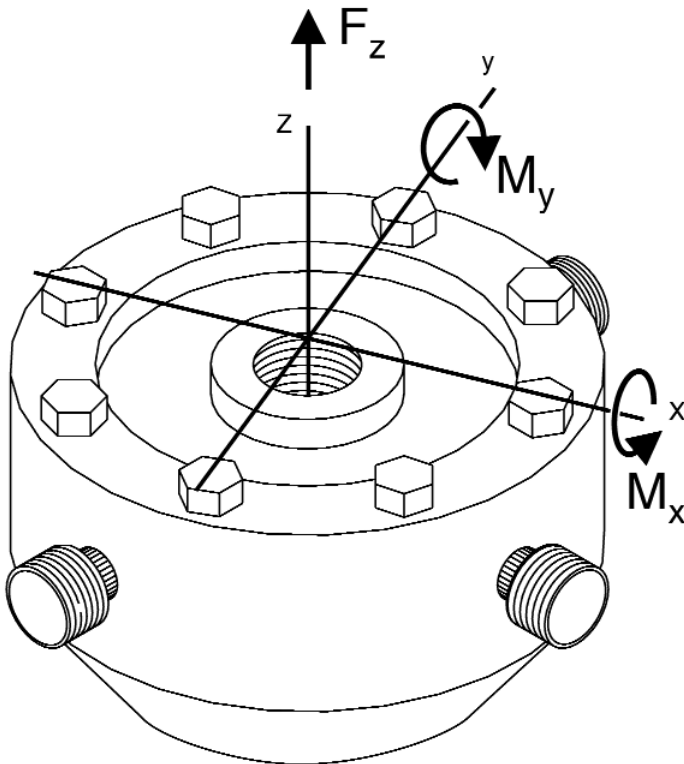

DIMENSIONS

	MODEL			
	5210		5220	
	CAPACITY (lbf)			
	1K, 2K, 5K, 10K		25K, 50K	
	inch	mm	inch	mm
	Same as 1200 Series Universal (See Page 18)			

5200 Model	Rated Thrust (lbf)	Rated Moment (in-lbf)
5210XYZ-1K	1,000	400
5210XYZ-2K	2,000	800
5210XYZ-5K	5,000	1,000
5210XYZ-10K	10,000	2,000
5220XYZ-25K	25,000	10,000
5220XYZ-50K	50,000	20,000