

Installation Instructions

1. The primary advantage of the Interface Flange Load Cell is that the hub of the load cell is mounted using several smaller screws instead of one large central thread. It is easier to preload multiple smaller screws than a single central thread. In certain applications it may not be possible to properly preload a central thread due to the torque limits of the load cell.
2. Interface Flange Series Load Cells must be mounted on a suitable surface that is flat and rigid enough so as not to deform appreciably under load. The mounting surface should have a minimum hardness of Rc 30-33. The mounting surface should be perpendicular to the load axis within 1 degree.
3. Interface load cells respond to forces in the axis perpendicular to the mounting surface. Load cell response to a non-axial force is proportional to that force times the cosine of the angle it makes with the loading axis.
4. When installing the load cells, Class 12.9 (or minimum 177 ksi tensile strength) screws should be used. For model 1710 and 1720 Load Cells, it is permissible to use Grade 8 or Class 10.9 screws. Torque the screws as indicated in Table 1 & 2.

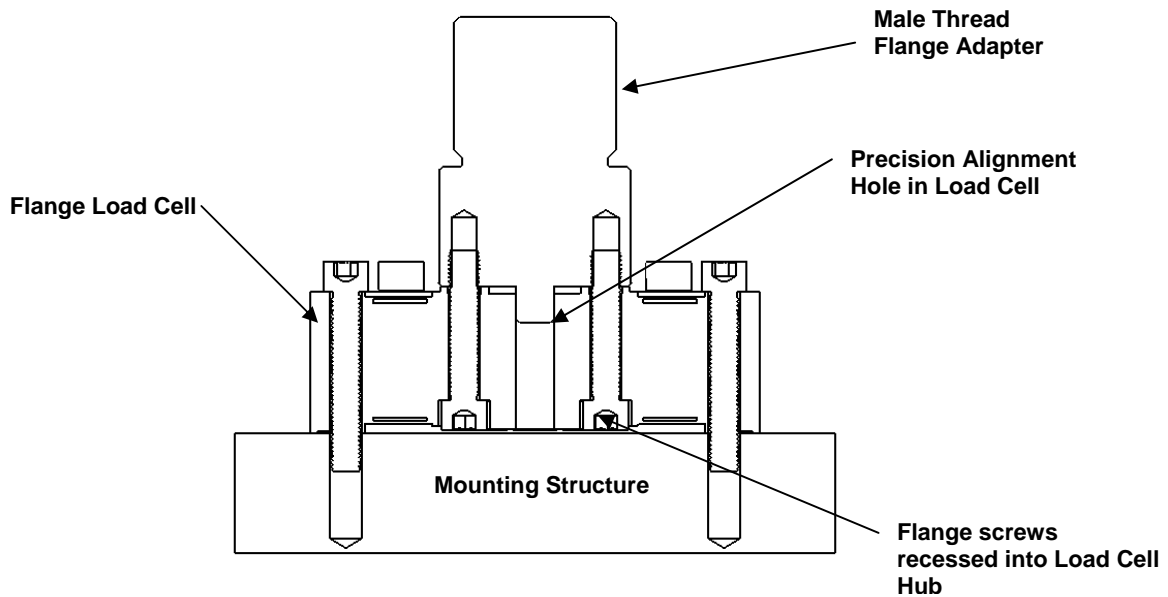

Table 1 - Flexure Mounting Screws

Model Number	Capacity		Flexure Mounting Hole		Flexure Screw Size			Flexure Screw Torque	
	US (lbf)	Metric (kN)	Diameter *	Bolt Circle *	Fractional	Metric	Length *	(lb-in)	(Nm)
1710	550, 1.1K	2.5kN, 5kN	.21 (5.3)	2.64 (67.0)	# 10-32	M5	1.25 (35)	45	5
1720	2.2K, 4.5K	10kN, 20kN	.26 (6.6)	3.15 (80.0)	1/4	M6	1.50 (40)	120	14
1730	11K, 14K	50kN, 63kN	.26 (6.6)	3.39 (86.0)	1/4	M6	1.50 (40)	120	14

Table 2 - Flange Mounting Screws

Model Number	Capacity		Flange Mounting Hole		Flange Screw Size			Flange Screw Torque	
	US (lbf)	Metric (kN)	Diameter *	Bolt Circle *	Fractional	Metric	Length *	(lb-in)	(Nm)
1710	550, 1.1K	2.5kN, 5kN	.21 (5.3)	0.79 (20.0)	# 10-32	M5	1.12 (30)	45	5
1720	2.2K, 4.5K	10kN, 20kN	.26 (6.6)	1.18 (30.0)	1/4	M6	1.25 (30)	120	14
1730	11K, 14K	50kN, 63kN	.26 (6.6)	1.18 (30.0)	1/4	M6	1.25 (30)	120	14

Table 3 - Hub & Mounting Ring Diameters

Model Number	Hub Diameter	Inner Mounting Ring		Outer Mounting Ring		Mounting Surface Flatness *
	"A" *	"B" *	"C" *	"D" *	"E" *	
1710	1.07 (27.3)	2.30 (58.4)	2.40 (61.0)	2.94 (74.7)	3.03 (77.0)	0.0002 (.005)
1720	1.57 (40.0)	2.83 (71.8)	2.95 (74.9)	3.63 (92.1)	3.74 (95.0)	0.0002 (.005)
1730	1.57 (40.0)	2.83 (71.8)	3.13 (79.4)	3.75 (95.1)	3.98 (101.0)	0.0002 (.005)

* = inch (mm)

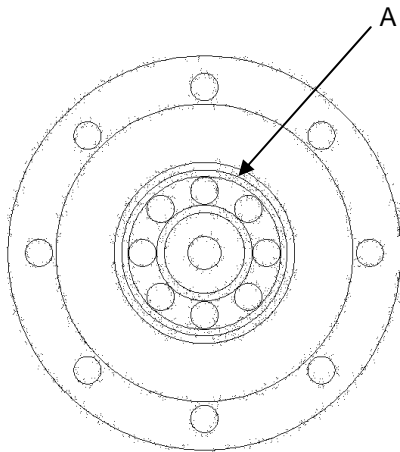

Top View

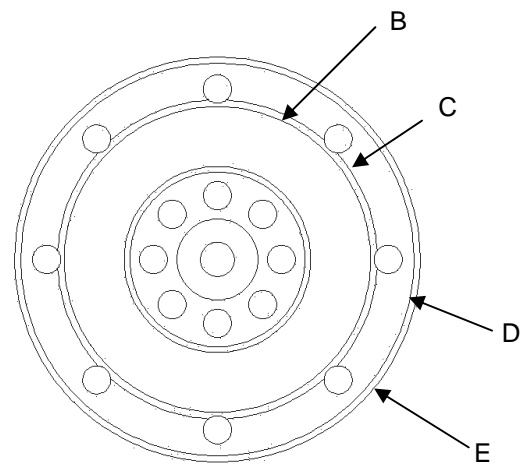

Bottom View